

BRUSHLESS DC PLANETARY GEAR MOTOR DM-42RPBL4260

典型应用/Typical applications :

自动快锁门、装订机、自动电视架、点钞机、聚光灯、卫生纸机、
办公设备、家用电器、自动执行机构

Auto shutter, binding machine, automatic TV rack, money counter,
spotlight, tissue machine, office equipments, household appliances,
automatic actuator

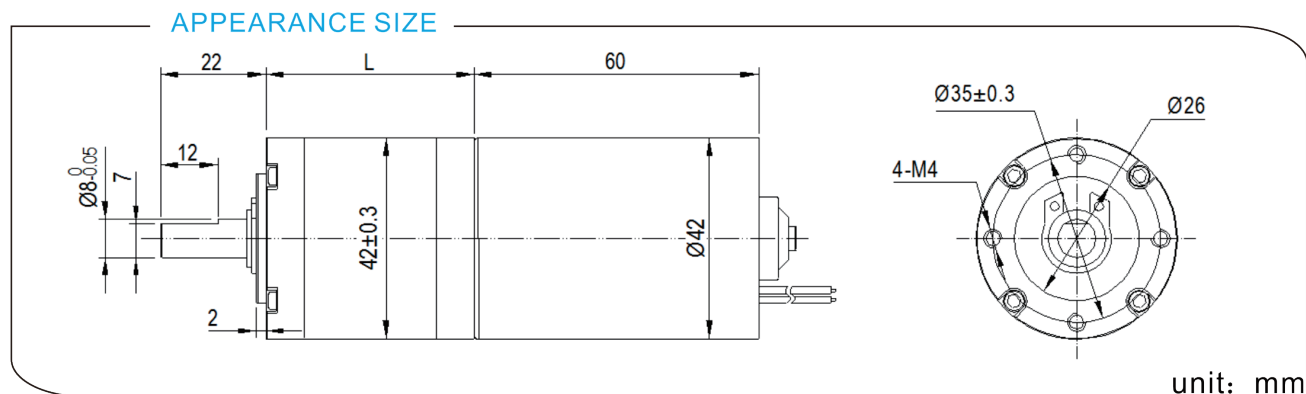
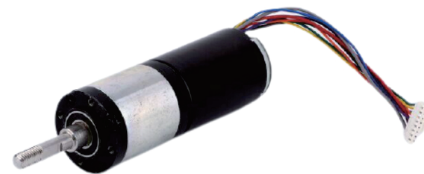

齿轮箱参数/Gearbox Data:

级数 Number of stages	1	2	3	4
减数比 Reduction Ratio i	3.7、5	13、18、25	49、67、92、125	181、246、336 458、625
齿轮箱长度 Gearbox Length L (mm)	33.2	43.6	54	64.4
破坏扭力 Breaking Torque(kgf.cm)	15	25	50	90
齿轮箱效率 Gearbox Efficiency η	90%	81%	73%	65%

电机参数/Driving Motor Data:

DC Motor Model	Rated	No Load		Max Efficiency Load			Stall		
	电压	电流	转速	电流	转速 (n _m)	扭矩 (t _m)	功率	扭矩	电流
	Volt.	Current	Speed	Current	Speed	Torque	P.out	Torque	Current
	V	mA	r/min	mA	r/min	gf.cm	W	gf.cm	mA
DM-BL4260-012-6000	12	≤320	6000	≤3700	3900	600	36.9	≥1710	≥5000
DM-BL4260-012-10000	12	≤900	10000	≤5300	7200	800	82	≥2800	≥10000
DM-BL4260-024-8000	24	≤380	8000	≤2200	6700	450	36.9	≥2760	≥9000
DM-BL4260-024-10000	24	≤620	10000	≤2860	8400	600	61.5	≥3750	≥5000

减数电机参数/Geared Motor Data :

Gear Motor Model	额定电压 Rated voltage	No load		Max Efficiency Load			Stall		
		电流	转速	电流	转速 (n)	扭矩 (t)	功率	扭矩	电流
		Current	Speed	Current	Speed	Torque	P.out	Torque	Current
		A	r/min	A	r/min	kgf.cm	W	kgf.cm	A
DM-42RPBL4260-0126000-246K	12	0.4	24.3	1.88	21.4	30.7	6.81	170.7	7.5
DM-42RPBL4260-01210000-13K	12	0.15	769.2	5.50	533.6	3.9	21.45	1887.6	14.09
DM-42RPBL4260-0248000-25K	24	0.55	320	3.12	272	1.1	31.61	284.5	11.85
DM-42RPBL4260-02410000-49K	24	0.11	204.08	5	160.6	2.3	38.88	354.8	14.76

电机参数仅供参考, 请以实际样板为准; 可以依据客户要求定制参数。

The motor parameters are for reference only, please refer to real measured data;

We can customize parameters according to customer requirements.

减数电机输出转速=直流电机输出转速/齿轮箱减数比; 减数电机输出扭矩=直流电机输出扭矩*齿轮箱减数比*齿轮箱传动效率。

Gear Motor Output Speed=DC Motor Speed/Gear Ratio (n=n_m/i)

Gear Motor Output Torque=DC Motor Torque*Gear Ratio*Gearbox Efficiency. (t=t_m*i*η)