

DC WORM GEAR MOTOR DM-58SW31ZY

典型应用/Typical applications :
自动快锁门、装订机、自动电视架、点钞机、聚光灯、卫生纸机、
办公设备、家用电器、自动执行机构
Auto shutter, binding machine, automatic TV rack, money counter,
spotlight, tissue machine, office equipments, household appliances,
automatic actuator

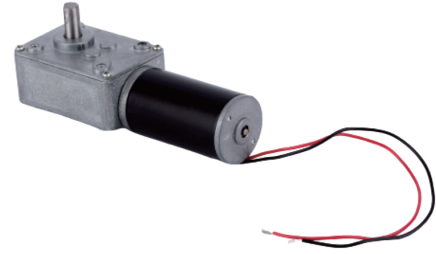

APPEARANCE SIZE

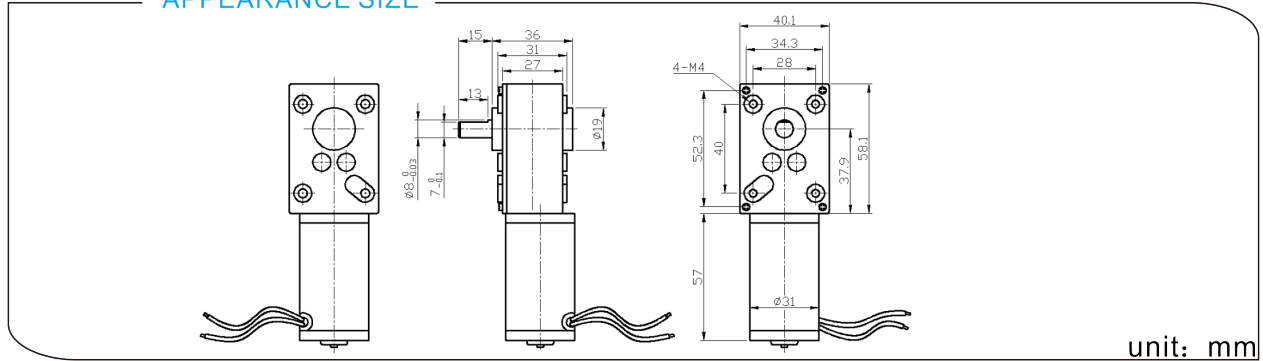

齿轮箱参数/Gearbox Data:

级数 Number of stages	3	4
减速比 Reduction Ratio i	54、75、109、161、167、322	313、405、402、500、548、663、708、1327
齿轮箱长度 Gearbox Length L (cm)	36	36
破坏扭力 Breaking Torque(kgf.cm)	15	35
齿轮箱效率 Gearbox Efficiency η	40%	36%

电机参数/Driving Motor Data:

DC Motor Model	Rated	No Load		Max Efficiency Load			Stall		
	电压	电流	转速	电流	转速 (nm)	扭矩 (tm)	功率	扭矩	电流
	Volt.	Current	Speed	Current	Speed	Torque	P.out	Torque	Current
	V	mA	r/min	mA	r/min	gf.cm	W	gf.cm	mA
DM-31ZY-012-3000	12	≤100	3000	≤400	2200	90	2.0	≥360	≥1600
DM-31ZY-012-4500	12	≤150	4500	≤700	3300	130	4.4	≥520	≥2700
DM-31ZY-012-6000	12	≤220	6000	≤1200	4500	180	8.3	≥720	≥5000
DM-31ZY-024-3000	24	≤60	3000	≤200	2200	90	2.0	≥360	≥800
DM-31ZY-024-4500	24	≤90	4500	≤350	3300	130	4.4	≥520	≥1300

减数电机参数/Geared Motor Data :

Gear Motor Model	额定电压 Rated voltage	No load		Max Efficiency Load			Stall		
		电流	转速	电流	转速 (n)	扭矩 (t)	功率	扭矩	电流
		Current	Speed	Current	Speed	Torque	P.out	Torque	Current
	V	A	r/min	A	r/min	kgf.cm	W	kgf.cm	A
DM-58SW31ZY-0126000-49K	12	0.14	123.6	0.84	104.4	2.7	2.87	17.0	4.67
DM-58SW31ZY-0126000-218K	12	0.12	25.8	0.94	21.8	10.6	2.37	68.0	5.41
DM-58SW31ZY-0129000-49K	12	0.36	181.5	1.93	146.5	3.7	5.64	19.0	8.52
DM-58SW31ZY-0128000-74K	12	0.15	106.9	0.83	86.4	5.7	5.09	29.9	3.66
DM-58SW31ZY-0248000-290K	24	0.13	26.3	0.73	22.5	19.4	4.47	132.0	4.20

电机参数仅供参考, 请以实际样板为准; 可以依据客户要求定制参数。
The motor parameters are for reference only, please refer to real measured data;
We can customize parameters according to customer requirements.
减数电机输出转速=直流电机输出转速/齿轮箱减数比; 减数电机输出扭矩=直流电机输出扭矩*齿轮箱减数比*齿轮箱传动效率。
Gear Motor Output Speed=DC Motor Speed/Gear Ratio (n=n_m/i)
Gear Motor Output Torque=DC Motor Torque*Gear Ratio*Gearbox Efficiency. (t=t_m*i*η)