

DC SPUR GEAR MOTOR DM-33RS385

典型应用/Typical applications :

自动快锁门、装订机、自动电视架、点钞机、聚光灯、卫生纸机、
办公设备、家用电器、自动执行机构

Auto shutter, binding machine, automatic TV rack, money counter,
spotlight, tissue machine, office equipments, household appliances,
automatic actuator



APPEARANCE SIZE

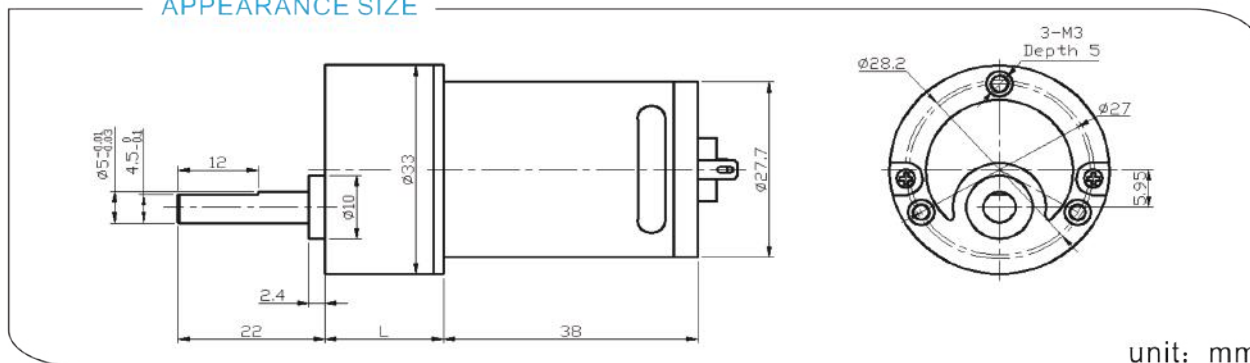

unit: mm

齿轮箱参数/Gearbox Data:

级数 Number of stages	3	4	5	6	7
减速比 Reduction Ratio i	20	50	125	312.5	781
齿轮箱长度 Gearbox Length L (mm)	17.7	19.9	22.2	24.4	26.75
破坏扭力 Breaking Torque(kgf.cm)	10	15	20	24	24
齿轮箱效率 Gearbox Efficiency η	73%	65%	59%	53%	48%

电机参数/Driving Motor Data:

DC Motor Model	Rated	No Load			Max Efficiency Load			Stall	
	电压	电流	转速	电流	转速 (n _m)	扭矩 (t _m)	功率	扭矩	电流
	Volt.	Current	Speed	Current	Speed	Torque	P.out	Torque	Current
	V	mA	r/min	mA	r/min	gf.cm	W	gf.cm	mA
DM-385-012-3000	12	≤60	3000	≤150	2200	35	0.8	≥110	≥360
DM-385-012-4500	12	≤70	4500	≤300	3300	55	1.9	≥210	≥960
DM-385-012-6000	12	≤100	6000	≤600	4500	80	3.7	≥280	≥1600
DM-385-024-3000	24	≤28	3000	≤70	2200	35	0.8	≥110	≥160
DM-385-024-4500	24	≤50	4500	≤150	3300	55	1.9	≥180	≥380

减数电机参数/Geared Motor Data :

Gear Motor Model	额定电压 Rated voltage	No load		Max Efficiency Load				Stall	
		电流	转速	电流	转速 (n)	扭矩 (t)	功率	扭矩	电流
		Current	Speed	Current	Speed	Torque	P.out	Torque	Current
	V	A	r/min	A	r/min	kgf.cm	W	kgf.cm	A
DM-33RS385-0124500-312.5K	12	0.07	15.1	0.21	11.4	6.0	0.75	26.0	0.64
DM-33RS385-01217500-50K	12	0.41	350.2	2.01	288	3.6	10.78	20.5	9.44
DM-33RS385-0246000-125K	24	0.07	46.7	0.24	37.4	5.5	2.11	27.4	0.93
DM-33RS385-0246000-312.5K	24	0.05	19.6	0.16	15.3	8.0	1.33	38.0	0.59
DM-33RS385-0247400-312.5K	24	0.07	23.3	0.29	19.6	11.1	2.24	50.0	1.5

电机参数仅供参考, 请以实际样板为准; 可以依据客户要求定制参数。

The motor parameters are for reference only, please refer to real measured data;

We can customize parameters according to customer requirements.

减数电机输出转速=直流电机输出转速/齿轮箱减数比; 减数电机输出扭矩=直流电机输出扭矩*齿轮箱减数比*齿轮箱传动效率。

Gear Motor Output Speed=DC Motor Speed/Gear Ratio ($n=n_m/i$)

Gear Motor Output Torque=DC Motor Torque*Gear Ratio*Gearbox Efficiency. ($t=t_m*i*\eta$)